

## 1. Check the Parts and Tools

### Parts Required

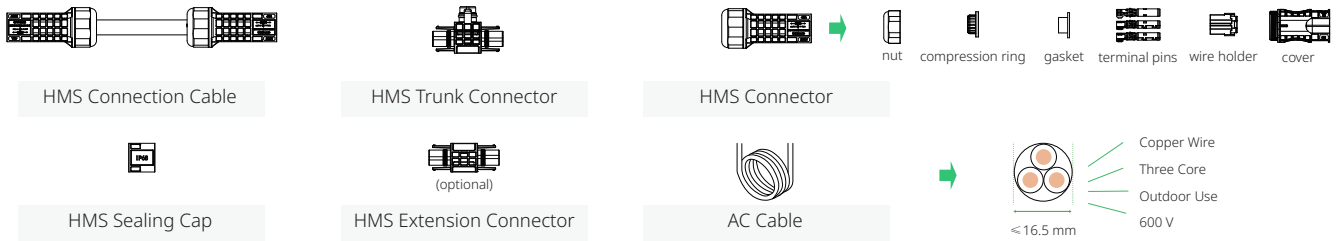

### Tools Required



## 2. Assemble the AC Trunk

This part gives a step-by-step guide for assembling the AC Trunk, which consists of the HMS Sealing Cap, HMS Connection Cable, HMS Extension Connector (optional), and HMS Trunk Connector as shown below.

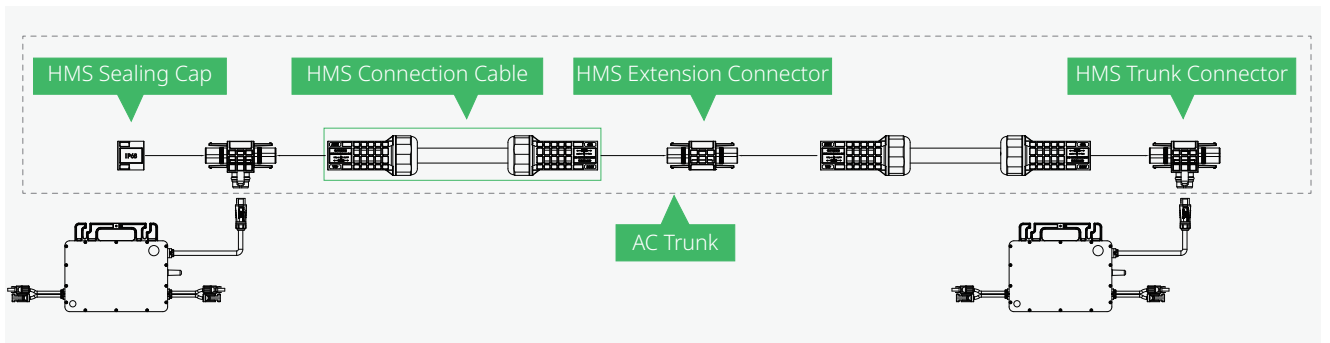

**Step 1** Connect the HMS Trunk Connector to the microinverter. Listen for a click as the connectors engage.

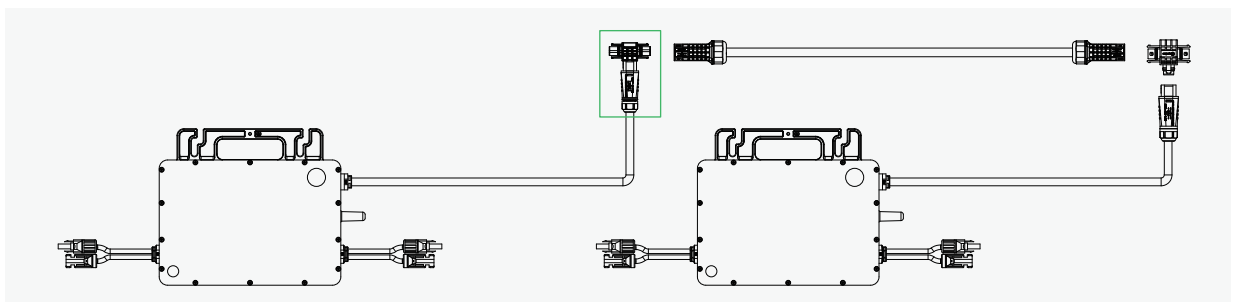
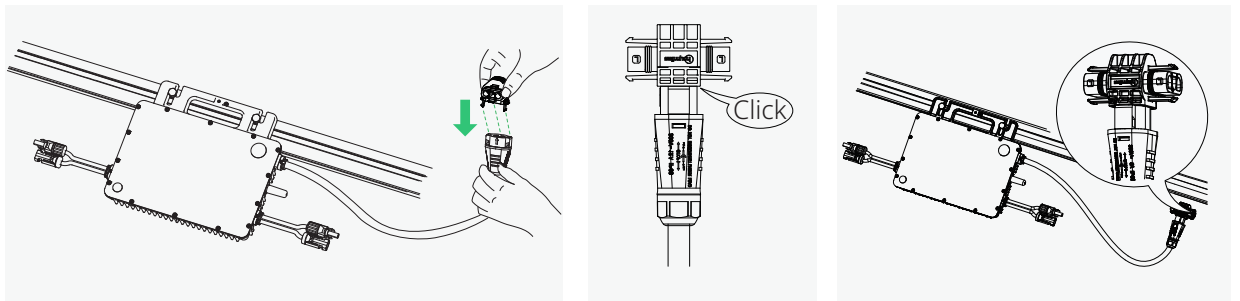

**Step 2** Cover the unused port on the HMS Trunk Connector (located at the beginning of the AC Trunk) with HMS Sealing Cap. Listen for a click as the sealing cap engages.

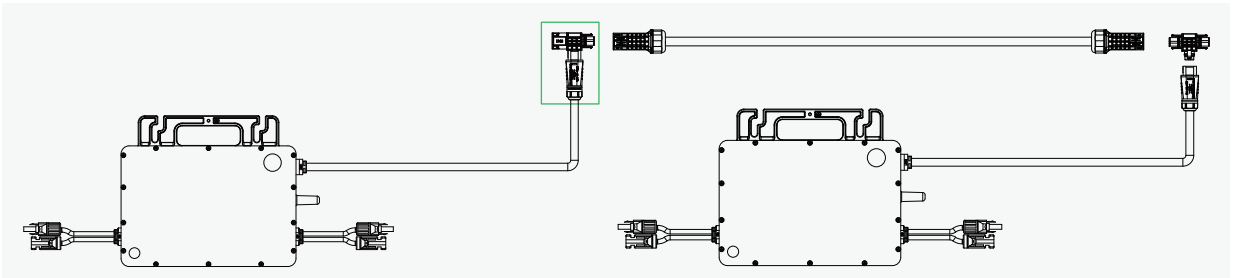
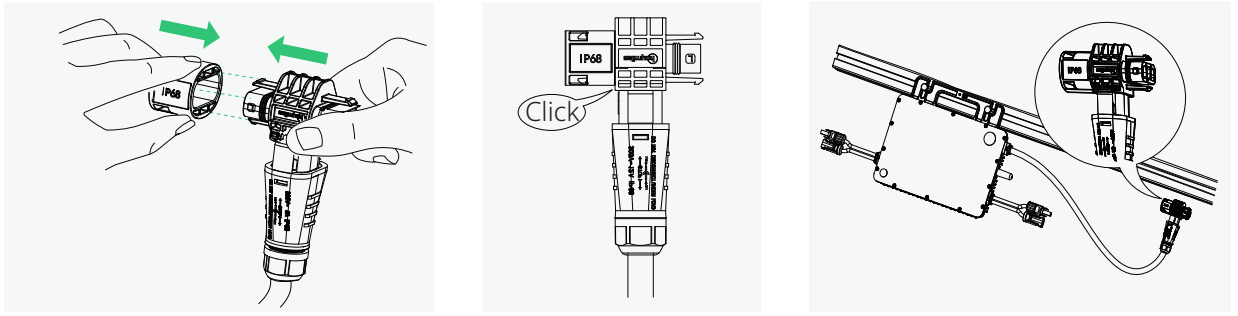

**Step 3** Use the HMS Connection Cable to connect the adjacent HMS Trunk Connectors. Listen for a click as they engage.

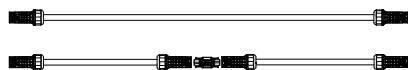
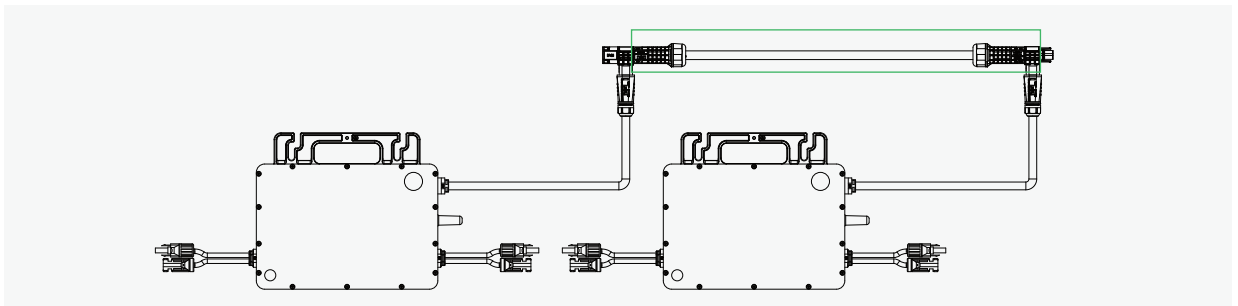
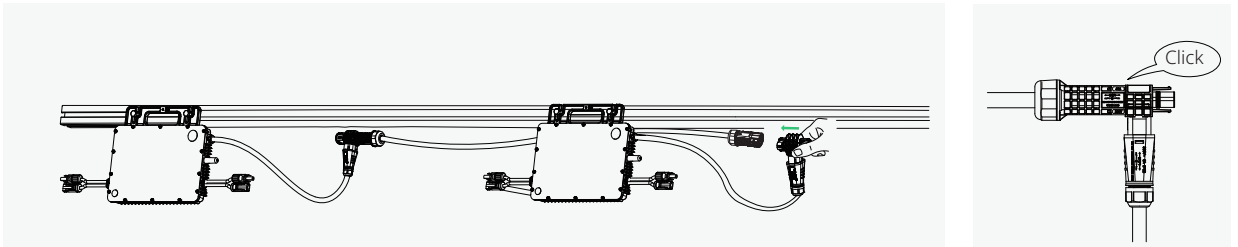
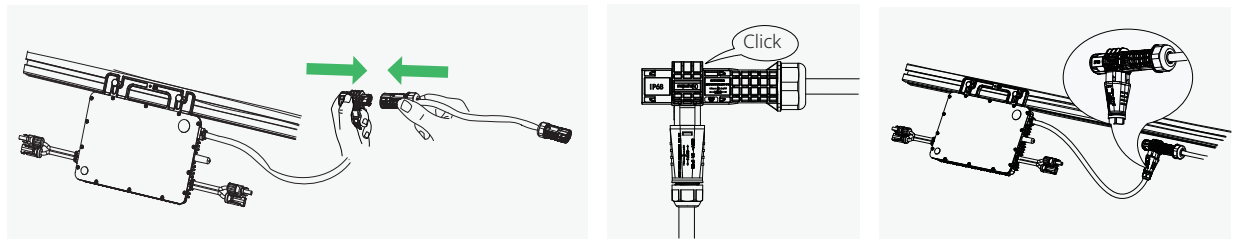

- If your microinverters are installed too far apart, Hoymiles provides two solutions: 1) use a longer HMS Connection Cable, 2) connect two HMS Extension Cables together using an HMS Extension Connector.
- Hoymiles provides a range of cable lengths including 1.1 m, 2.0 m, 2.3 m, and 4.6 m. If your desired length is not listed, please contact our sales or distributor to order cables of different lengths.
- The HMS Extension Connector is used to connect two HMS Connection Cables, while it's optional and not typically required. You can order it from Hoymiles if needed.
- Always comply with local standards when designing and installing cables.

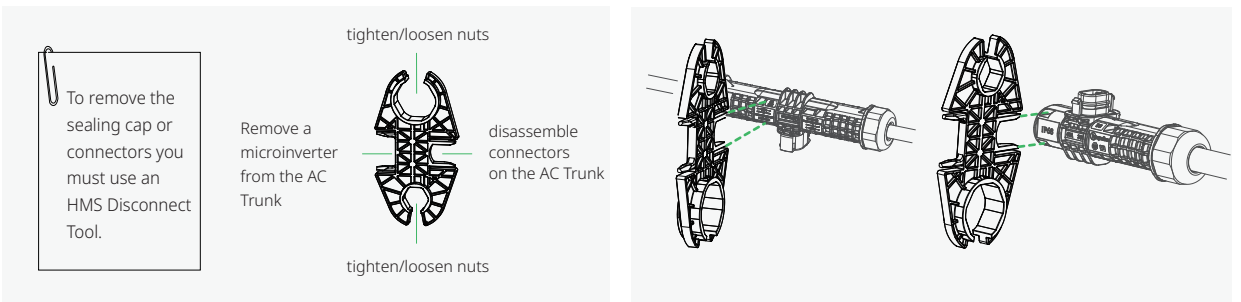
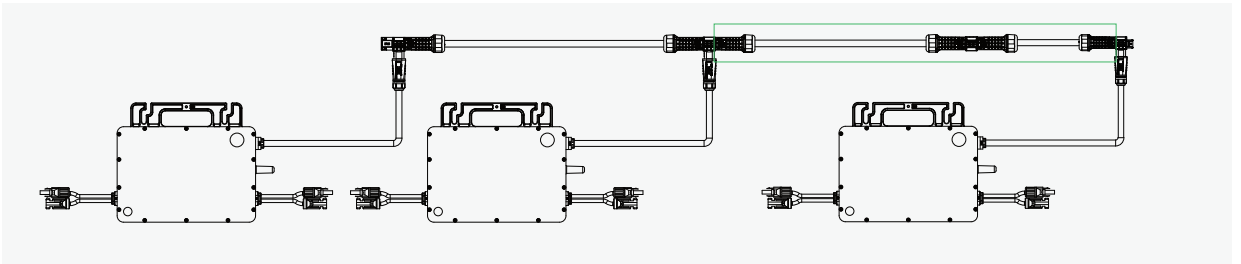
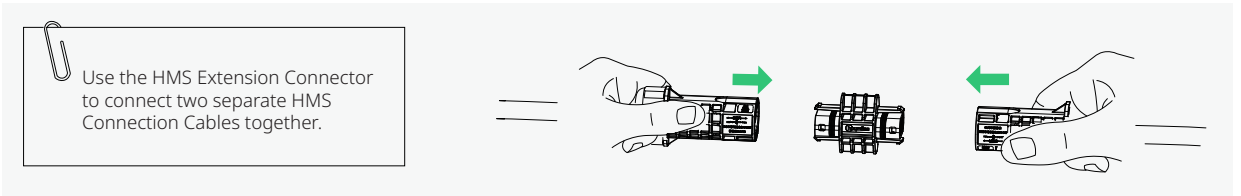

## 2. Make the AC End Cable

**Step 1** Before stripping the cable, make sure the HMS Connector can be separated into six parts.

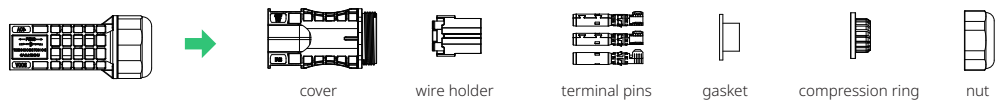

**Step 2** Push the parts through the AC cable in the correct order.

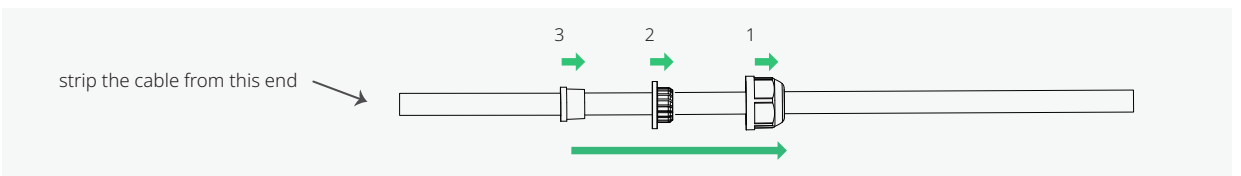

**Step 3** Strip off 30-31 mm of the outer jacket with a diagonal cutter. Then use a wire stripper to strip the insulation to expose 6-7 mm of the conductor. (Note: Take care not to cut individual conductor strands.)

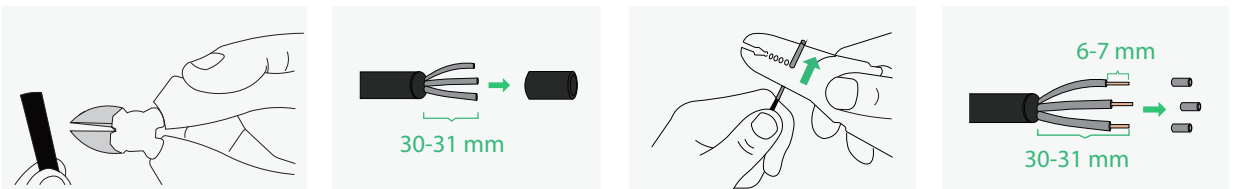

**Step 4** Insert the conductors into the terminal pins, crimp the connection, and push the crimped cable through the wire holder.

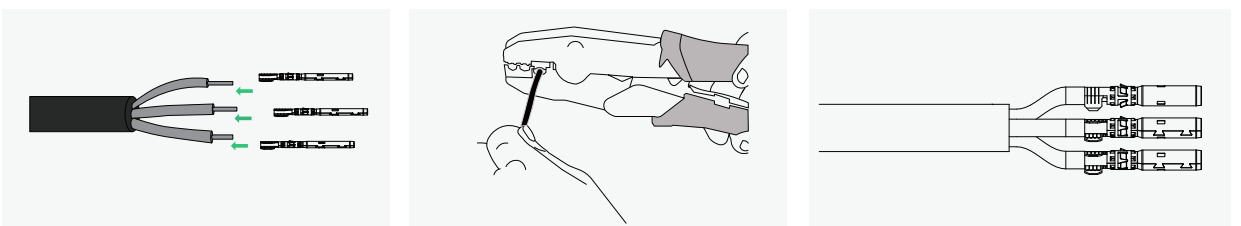

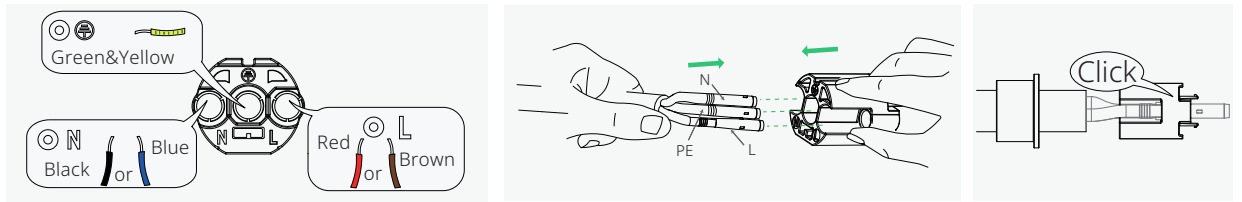

**Step 5** Plug the fixed cable into the HMS Connector. Then Firmly tighten the nut with a torque wrench.

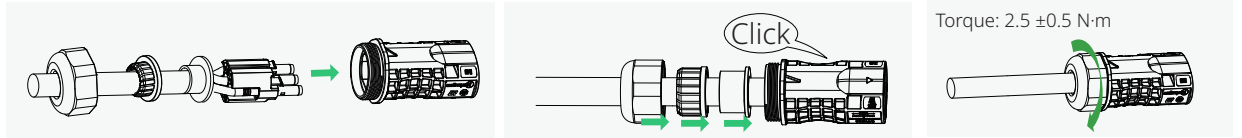

## 4. Connect the AC End Cable to the AC Trunk

**Step 1** Connect the AC End Cable to the last HMS Trunk Connector in a series of cables. Listen for a click as they engage.

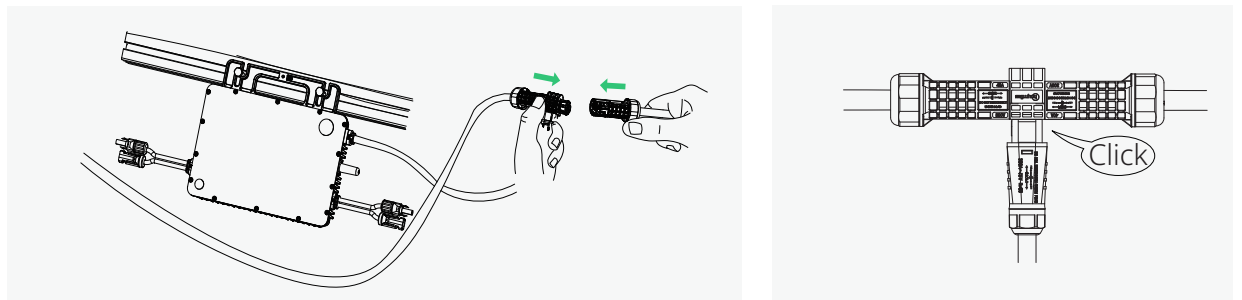

**Step 2** Use the cable ties to attach all cables to the raking.

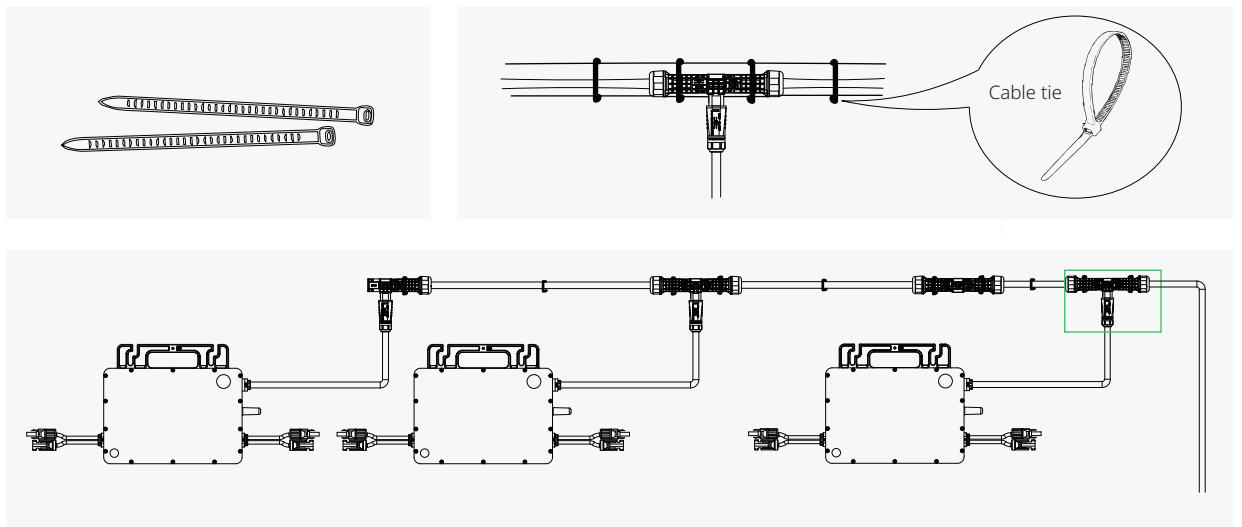

## 5. Connect the other end of the AC End Cable to the Distribution Box

